

Stephens



PONY EXPRESS



	MEMBER ASSOCIATION OF AEM EQUIPMENT MANUFACTURERS
CONTROL SYSTEMS CSMD MANUFACTURERS DIVISION	CONCRETE PLANT CPMB MANUFACTURERS BUREAU



Stephens

CONCRETE PLANTS • Tompkinsville, KY

*Stephens Proudly Supports
The Future of Concrete*



CIM
CONCRETE
INDUSTRY
MANAGEMENT

Middle Tennessee
State University

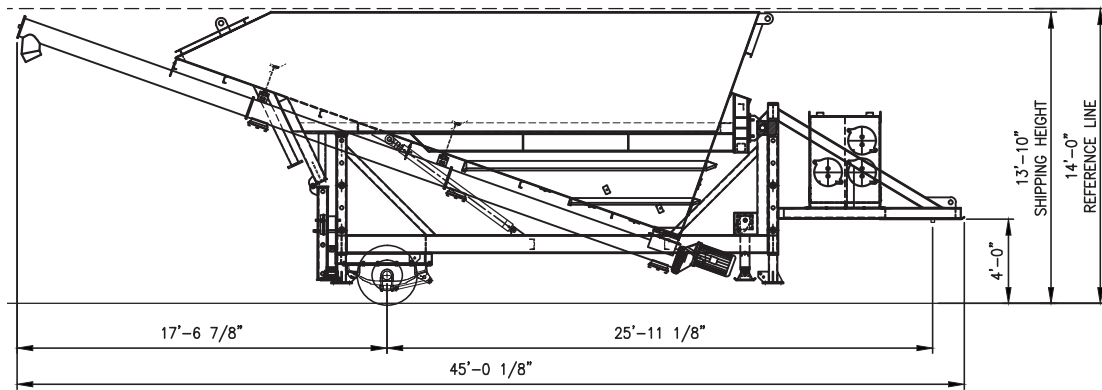

PONY EXPRESS: SHIPPING LAYOUT

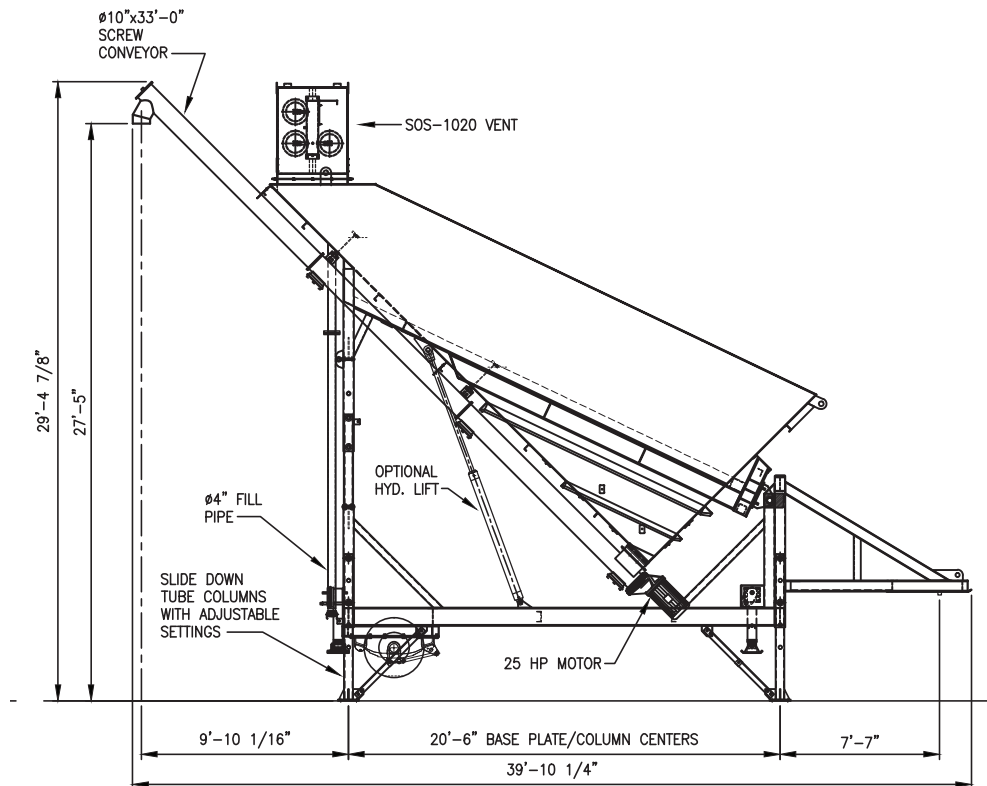

SIDE ELEVATION

STANDARD EQUIPMENT

- 412 BBL – 1648 CUBIC FEET
- 4" DIAMETER FILL LINE
- SV-265 SILO FILTER VENT
- HI AND LOW LEVEL INDICATORS IN SILO
- FOUR MECHANICAL LEVELING JACKS
- ONE SINGLE AXLE TRANSPORTATION SYSTEM
- 8" x 33' SPLINE DRIVE SCREW CONVEYOR

OPTIONAL

- LARGER SCREW CONVEYORS 10" & 12"
- LARGER SILO DUST COLLECTORS (SOS-1020 CARTRIDGE VENT)
- LOW PRESSURE AERATION BLOWER (STRONGLY RECOMMENDED)
- GAS & ELECTRIC HYDRAULIC PACKAGES FOR SELF ERECTING